

BW4-CTM (CE / USA/CA)

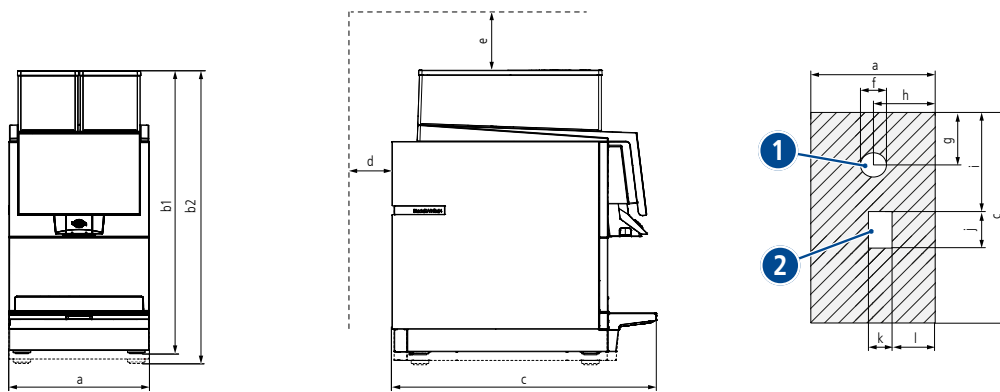

1 Cut-out for water/milk inlet and water drain. Also possible for power cord. 2 Cut-out for grounds ejection.

a	320 mm / 12.59 in	c	600 mm / 23.62 in	f	70 mm / 2.75 in	i	281 mm / 11.06 in
b1	CE: 646 mm / 25.43 in (feet: 57 mm / 2.24 in) or optional 676 mm / 26.61 in (feet: 87 mm / 3.42 in)	d	50 mm / 1.96 in	g	150 mm / 5.9 in	j	106 mm / 4.17 in
b2	USA/CA: 676 mm / 26.61 in (feet: 87 mm / 3.42 in)	e	350 mm / 13.77 in	h	160 mm / 6.29 in	k	63 mm / 2.48 in
						l	111 mm / 4.37 in

Drain

- **m**: Distance machine to drain < 1000 mm / 39.37 in.
- Drain line (hose) not sagging.
- No back pressure in the water line.
- The end of the line not submerged in water.

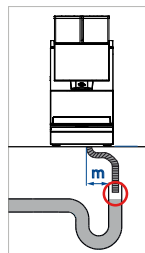

Refrigerator milk suction hose

- Length of refrigerator milk suction hose = 1200 mm / 47.24 in or 2200 mm / 86.6 in. Position the refrigerator close enough to the coffee machine.
- Height difference between the lower part of the refrigerator and the coffee machine < 1000 mm / 39.37 in.

Machine parameters		Water connection specifications	
Connection / Power CE	Machine with one phase (limited power): 220-240 VAC / 50-60 Hz 3100-3700 W / 16 A 220-240 VAC / 50-60 Hz 2700-3100 W / 13 A Machine with one phase: 220-240 VAC / 50-60 Hz 5800-6600 W / 32 A Machine with three phases: 380-415 VAC / 50-60 Hz 5800-6600 W / 3 x 16 A	Water connection	3/8"
Connection / Power USA/CA	208 VAC / 60 Hz 5700 W / 27 A	Dynamic water pressure	0.2-0.4 MPa (2-4 bar) / 30-60 psi (required operating pressure)
Outlet height	85-172 mm (manual) / 100-190 mm (autom.) 3.34-6.77 in (manual) / 3.93-7.48 in (autom.)	Max. water inlet pressure	1 MPa (10 bar) / 145 psi (if the pressure exceeds 4 bar, a pressure reducer must be used)
Weight	58 kg / 127.86 lbs	Water boiler pressure	11.7 bar / 169.6 psi
		Steam boiler pressure	2.6 bar / 37.7 psi
		Chlorine	None
		TDS	70-200 ppm
		Total hardness	5-8 °dH / 8-14 °fH
		pH	6.8-7.4
		Alkalinity	<100 ppm
		Iron	<0.25 ppm